

SL20M plissé

SL22M plissé

PLEATED BLIND



ScreenLine

SL20M plissé

SL22M plissé

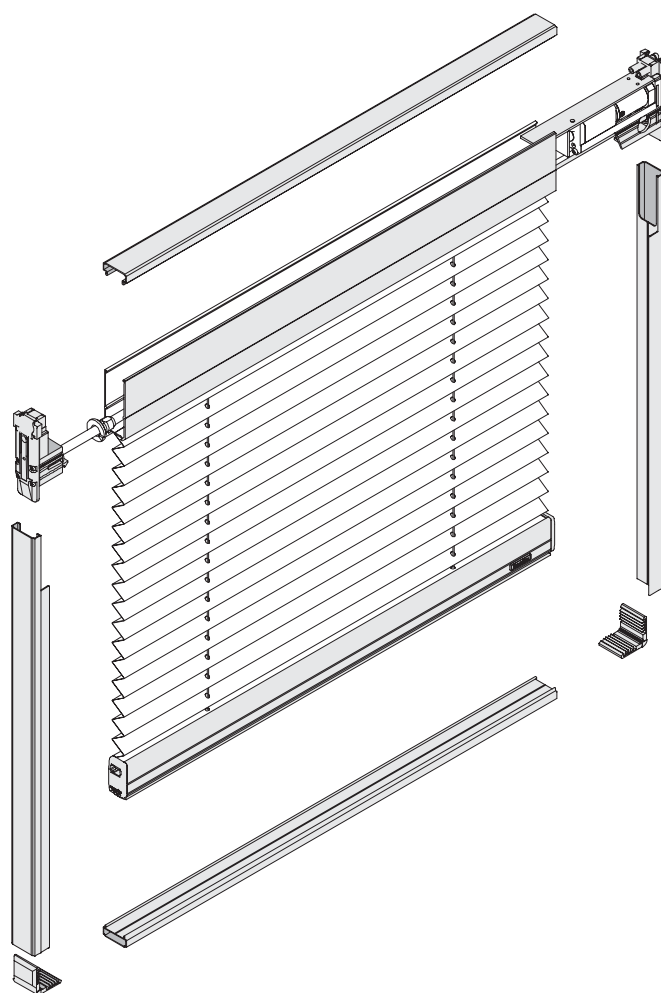

The ScreenLine® SL20M or SL22M pleated blind with motor inside the head rail for incorporation within a double-glazed unit, is manufactured in accordance with high technical specification and production standards.

The blind raising / lowering functions are achieved by way of an encoder motor that permits a constant speed resulting in a guaranteed synchronized function for multiple blinds. Special software determines the setting of blinds end stops, by a process of self-learning. The motor has two speeds. The blind slows before reaching the top and bottom limits in order to avoid excessive stress on the cords and to guarantee a longer life to the components. Faster speed for raising and lowering. The motor and the entire electronic blind management system are positioned within the head rail, on a specially designed slide incorporating a shock absorber system to reduce any vibration and significantly reducing any “noise” effect. The slide is also equipped with a specially integrated electric socket with a snap-in connector to the spacer bar allowing connection to the external power supply, thereby maintaining a complete hermetic seal to the unit. The motor is installed inside the head rail at a higher level in respect of the winding system and the drive is transmitted through a “special” corner key; this system allows the position of the first hole in

1. technical features

the fabric to be nearer to the extremities, guaranteeing better blind stability. The electrical system incorporates a polarity inverter allowing the raise and lower function of all the connected blinds to be fully synchronized using only two wires. A mechanical end-stop incorporated within the head-rail, ensures a safety stop of the blind at the lowest position. The entire kit is contained within the spacer bar frame, guaranteeing the hermetical seal of the system.

Height	300 ~ 2500 mm
Width	300 ~ 1500 mm
Maximum area	see feasibility table
Blind stack height	2% blind height + 80 mm

Motor groups

24V dc power supply, maximum absorption: 300mA.

Operation speed: 50 rpm.

Torque: 0,8 Nm

Motor

F class winding (155°C); brushes in 50% CU, 47% C, 3% MoS₂; diamond finished commutator.

Reducer

Planetary manufactured in steel. Cogged gears, external broached rim, planetary supports with guide rollers, double bearings in output.

Total Ratio: 214:1 (95:1 in the reducer; 2,25:1 in the corner key)

Encoder

Magnetic encoder in Neodymium, with a very high magnetic field with a resistance strength up to 120°C. Fixed firmly on the motor shaft via a brass ring.

Electronic card

Manufactured from standard industrial components. Operating range (-20°C + 100 °C) and controls the encoder, the speed limiter and the motor safety function. Motor and electronic chart are fixed on the plastic slide.

Head rail

Extruded aluminium, A6063S-T5 alloy.

Dimensions: width 20 mm, height 54 mm with 5 mm pelmet

High-resistance polyester paint. Available colours: aluminium grey, white and beige.

Verosol® fabric

Woven polyester fabric, 14 mm pleat, with an aluminium microfilm applied through an exclusive vacuum technique (three-chamber system). The microfilm adhesion complies with the EN-ISO 7523 regulations and the fabric is Class 1 (one) Flame-Retardant. Colours available: 6.

Vanity fabric

Woven polyester fabric, 14 mm pleat, non flame retardant, not metallised. Colours available: 2.

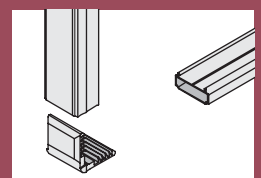
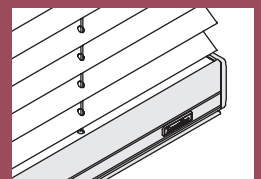
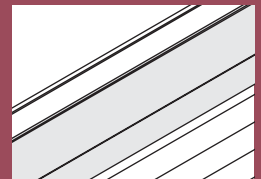
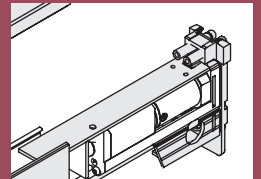

SL20M plissé

SL22M plissé

Performance characteristic of the Verosol® fabric

Pleated Verosol® Fabric	Solar reflection %	Light reflection %	Solar absorbing %	Solar transmission %	Light transmission %
812	71	66	20	9	9
816	52	50	28	20	22
878	74	74	21	5	5

Performance characteristic of the Vanity fabric

Pleated Vanity Fabric	Light reflection %	Light absorbing %	Light transmission %
White C000	46	4	51
Cream C010	40	13	46

Bottom rail

Extruded aluminium A6063S-T5 alloy.

Dimensions: width 14 mm, height 30 mm.

Manufactured in two interlocking profiles.

Powder coated to colour aluminium grey, white or beige.

Internal cord

Thermo-fixed 100% polyester internal cord, with excellent dimensional stability. 1.0 mm diameter – colour white. High resistance performance and very little shrinkage effects at high temperature.

Spacer bar

Extruded aluminium.

SL20C System Dimensions: 20 x 6,5 mm; Upper: extruded open spacer bar; Lower: extruded "U" shaped spacer bar with 2 mm clipping projection; Sides: "L" shaped side spacer with 8 mm projection on one side.

SL22C System Dimensions: 22 x 6,5 mm; Upper: extruded open spacer bar; Lower: extruded "U" shaped spacer bar with 2 mm clipping projection; Sides: "C" shaped side spacer with 8 mm projection on each side.

Control accessories

Control unit

For use in the application of centralization of several blinds or bus control.

It is possible to connect a maximum of 4 blinds. Possible connections: power supply, single switch and remote signal from other control units, and output to motor. Due to its small dimensions (40x40x20 mm) it can be easily contained in the wall electric box. Equipped with internal safety fuse 6,3 A.

Power supply

230V AC Mains voltage input / 24V DC +/- 5% output, 2A. Protection fuse 3,15 A delayed, for maximum 4 blinds. Dimensions: 110 (130 mm with fixing projections) x85x50 mm (height)

SL20M plissé

2. technical drawings

comprehensive drawing with component codes

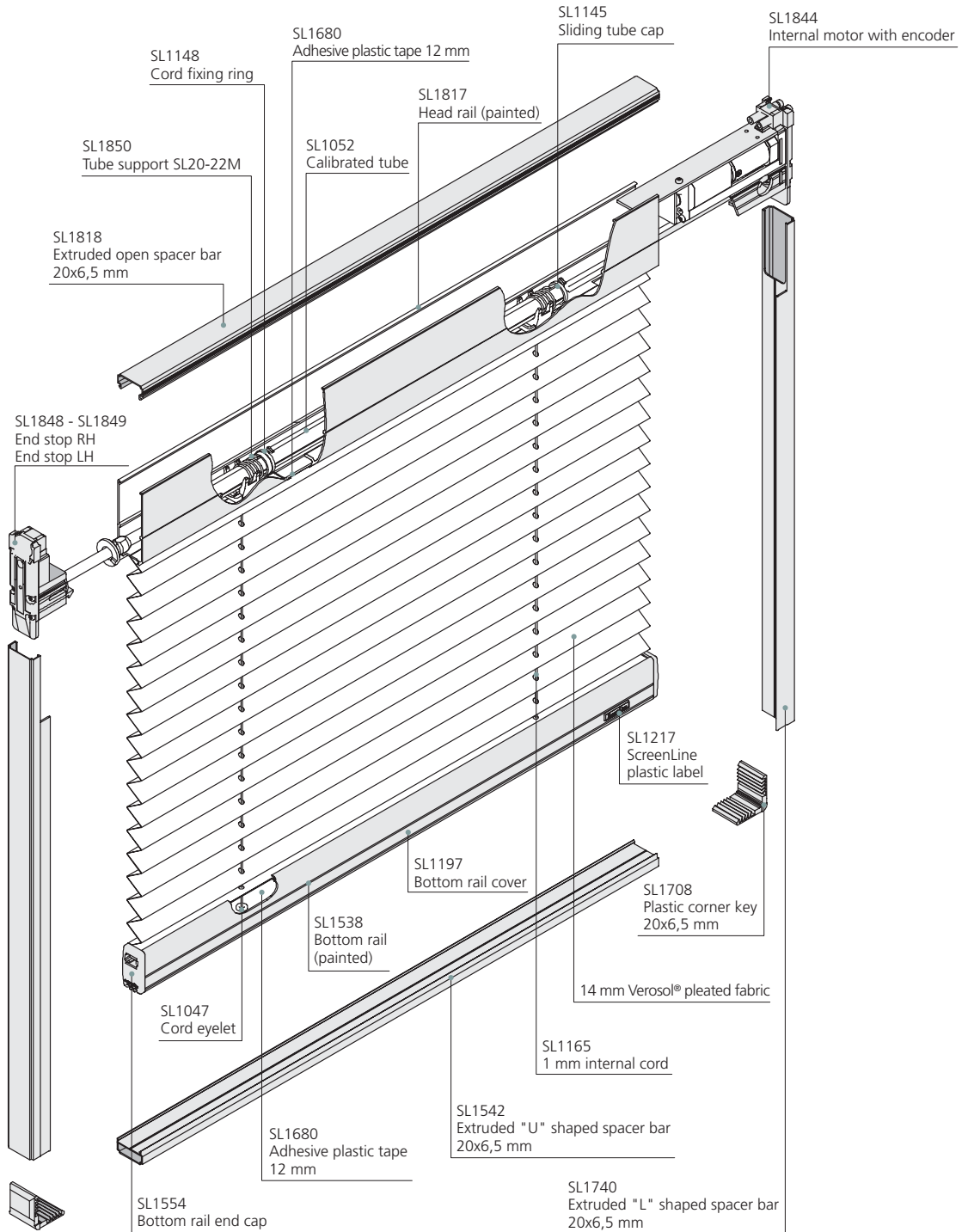

SL22M plissé

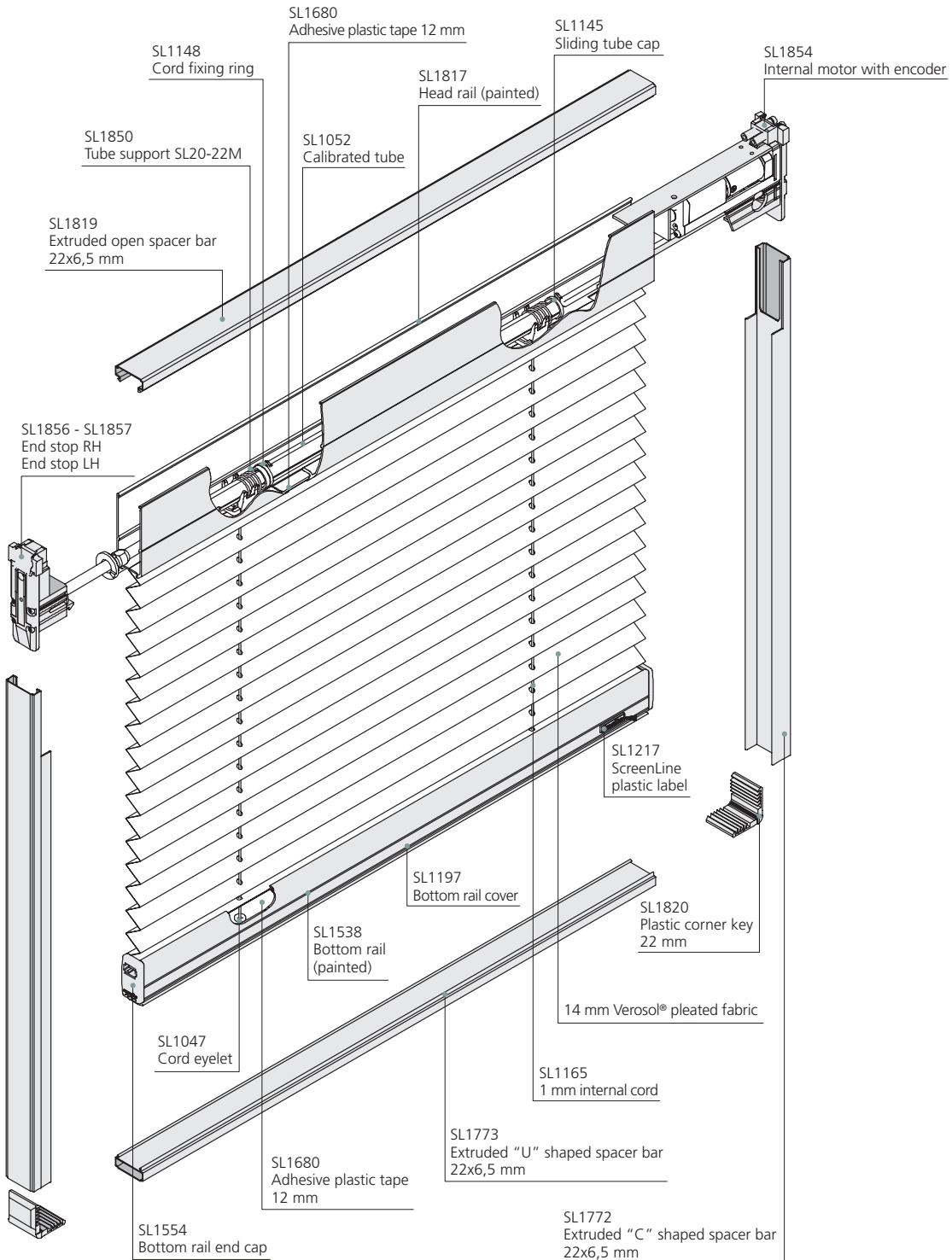

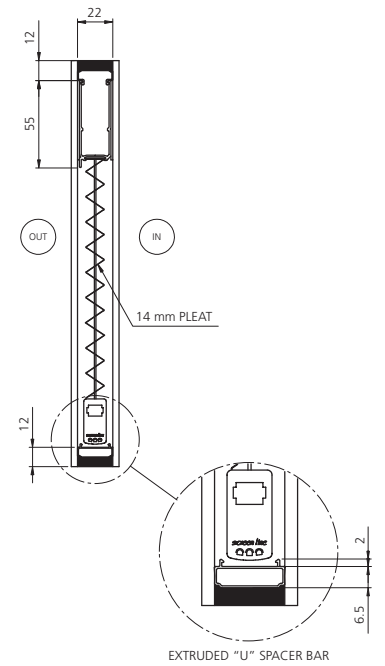
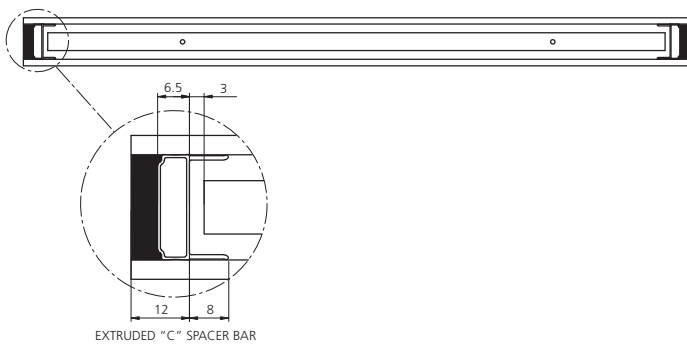
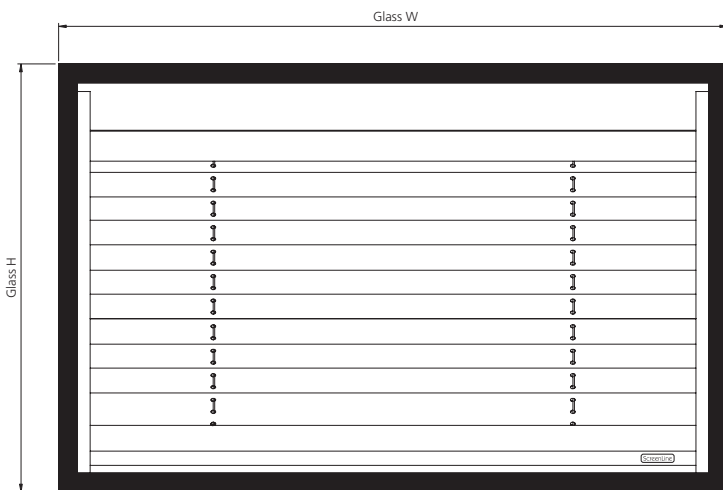
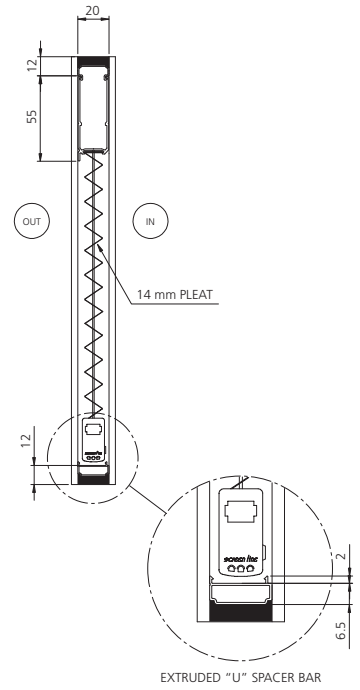
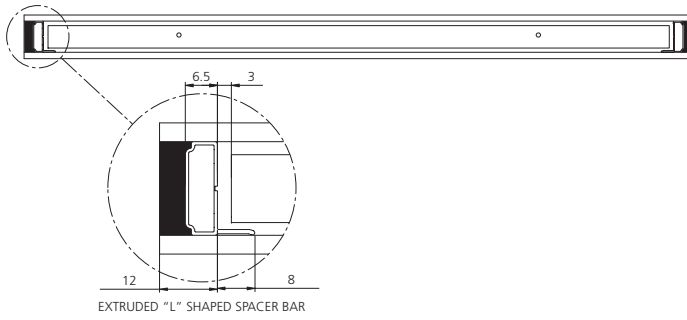
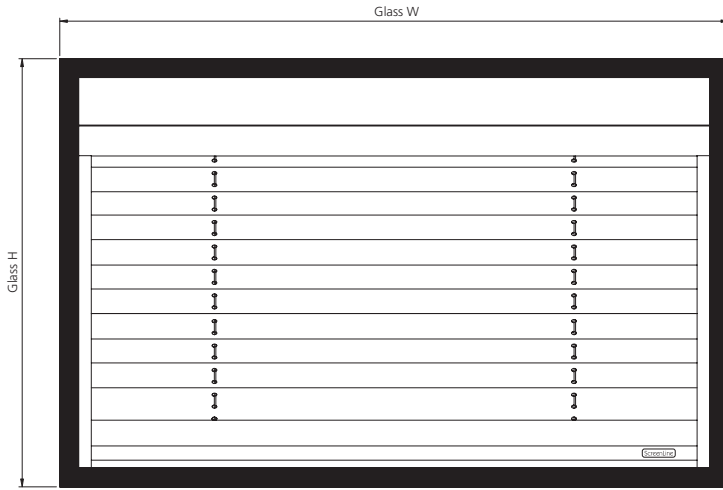

SL20M plissé

SL22M plissé

3. feasibility

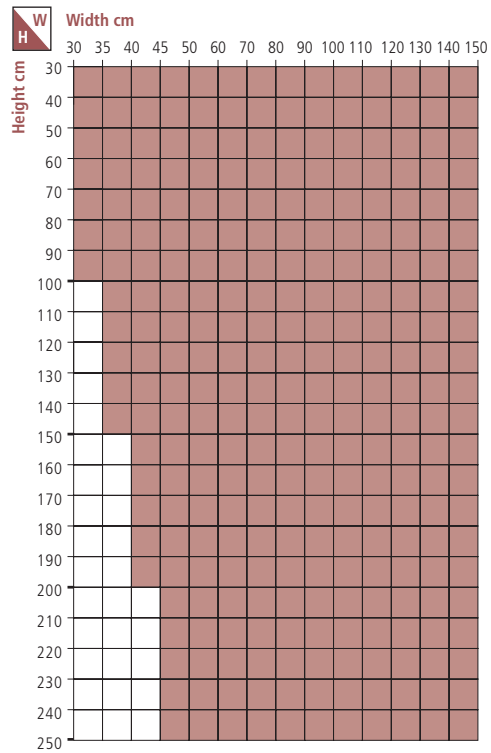

Feasible

Not feasible

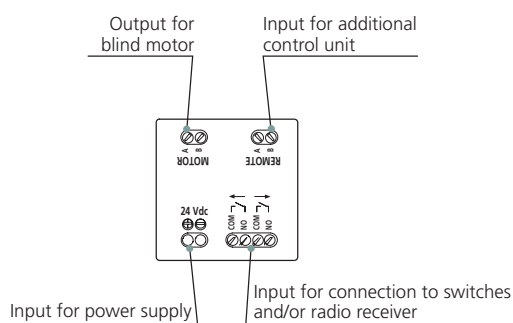
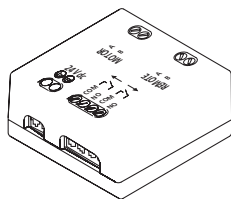

SL1807 Control unit

This unit is used to control the polarity inversion necessary for the correct function of the motor, which would not be realised when using normal switches.

Each control unit can control one blind, or can simultaneously control a group of up to four blinds, depending on the requirements of the system.

The limited dimensions of the unit allow its insertion inside the standard electrical back box.

It comprises an electronic card equipped with a protection fuse that can be easily replaced.

Technical features

Dimensions (mm)

40x40x20

Input

- supply, marked as **24V dc**
- connection to the double switch or to the radio receiver, marked by a contact graphic
- connection from another control unit, marked as **REMOTE**; this is used only for centralised connections to other groups (see note below)

Output

- connection to the blind motor or to a bus line for connection towards other control units; marked as **MOTOR**

Fuse

6,3 A

Working temperature

-20 +60°C

Note

The **REMOTE** terminal is available to allow the installer the opportunity to meet the client's requirements for a variety of group control combinations. This is achieved by connecting the **REMOTE** terminal to the **MOTOR** output terminal of another SL1807 CONTROL UNIT. A typical application would be where a single control is required for a number in blinds already controlled individually by a control unit. By connecting a new control unit via the **MOTOR** output in parallel with all the **REMOTE** terminals of the existing control units involved in the total operation, the additional control unit, once has been activated, will control all the control units simultaneously, whilst still allowing control of each motor separately.

Multiple control systems can be built up using this procedure.

SL1868 Power supply

This power supply unit has been specially developed for the SL27M motor. It comprises two external brackets for wall fixing and two internal terminal blocks – one for the main's power supply connection and the other for the 24V dc output. It can supply up to a maximum of 4 motors.

Technical features

Dimensions (mm)

110 (130 included fixing fins) x85x50 (height)

Type

Switching

Output

24V dc \pm 5%

Maximum current output

2 A

Internal protection fuse

3,15 A delayed

Working temperature

-20 +60°C

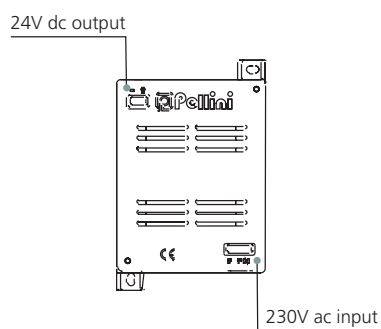
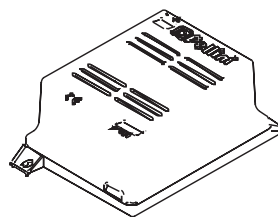

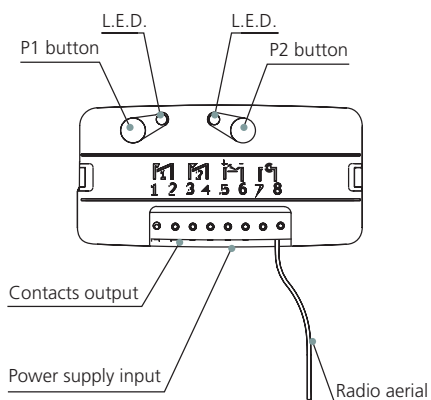
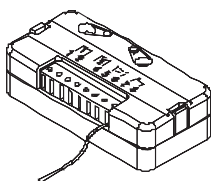
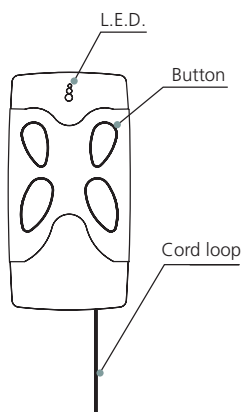
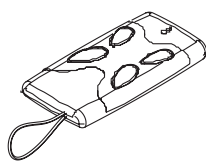

Remote control

The remote control for the SL20 – SL22M system is by radio control, FM, comprising a transmitter and a receiver.

SL1821 Transmitter

Can control a single group of blinds or two groups of blinds. It has 4 channels linked to switches and a L.E.D. display.

Technical features

Dimensions (mm)

67x34x8 (height)

Battery

CR2032

Frequency

433.920 MHz

Number of possible combination

266

Channel

No. 4

SL1822 Receiver

It has only two channels (UP/DOWN) and therefore it is able to control only one control unit.

Its terminal board allows connection to the 24V dc low tension power supply and to the contact out-put terminals. It incorporates two switches and two L.E.D. signals for the transmitter program function.

Technical features

Dimensions (mm)

79x48x21 (height)

Power supply

24Vac/dc

Stand-by consumption

40mA

Working temperature

-20 +60°C

Code memorisation ability

500

Channel

No. 2

Remote control programming

The receiver of the remote control must be programmed during installation in order to be connected to the signals from the transmitter.

The receiver is equipped with a programming procedure to automatically recognise the transmitter (self-learning); this is simply achieved by pressing the button on the receiver.

It is possible to programme the functions of the single button of the remote control.

Receiver programming procedure

Press the 'P1' button located on the receiver and the respective L.E.D. will flash 5 times.

During this flashing period, press one of the transmitter buttons to memorise the position.

The L.E.D. on the receiver will now continuously flash for 3 seconds to confirm positive record of setting.

To set channel 'P2', on the receiver repeat the above operation, using the other button located on the transmitter.

Electric connection to the blind

Connect the two-core cable with the attached ring connectors to the terminals located in the top right corner key (top left on request), using the 2 No. screws provided. For this procedure, please see the picture sequence present on the assembly instructions (H1 & H2).

During this operation please ensure that the screws are fully tightened to avoid bad connection and subsequent malfunction.

Cover the area around the connection with more secondary sealant to ensure no possibility of water penetration creating a short circuit after glazing.

Ensure that there is no possibility of the wires being damage by the framing system causing a short circuit.

Function of the blind

The system SL20M – SL22M pleated must be connected to a power supply sufficient to ensure a constant 24V dc supply to all the connected motors.

The electronic card, contained inside the blind, controls the several functions, one of which controls the stop position corresponding to the end stop of the top and bottom positions.

The dedicated software provides two speeds. Slow speed to stop the motor slowly as the blind approaches the end stops, and a higher speed for the raising and lowering function.

The blind function (Up / Down) is activated by switching the power supply (inversion).

It is possible to control the up / down inversion using a rocker switch (two way retractable – centre off), or by a double commutator switch, or alternatively by remote radio control.

- Using a double commutator switch (i.e. Vimar – Idea serie – code 16145), it is possible to connect all the blinds to be controlled simultaneously with only two wires.
- A standard rocker type switch should be used in conjunction with a dedicated "control unit". This system will allow any group of up to 4 blinds to be controlled together using only two wires.

- Remote radio control should also be used in conjunction with a dedicated 'control unit'.

The following selection of wiring diagrams indicates the wide variety of possible combinations.

To raise/lower the blind, by pressing the switch continuously, the speed will change from the slow speed to the fast speed for raise/lower. Once the fast speed is reached, the button can be released and the blind will automatically continue to its stop position (top or bottom). This procedure increases the "life" of the system, since it avoids any excessive stop/starts. When using a commutator switch, the button will need to be depressed until the blind reaches the desired position.

To stop the stroke of the blind, give one impulse to either the UP or DOWN button or move towards the centre for the double inverter.

Setting of the blind end stops

The motor has a self-learning process: the blind, during the raise and lower operation is able to recognise the extreme positions and to memorise them. Once these limits are memorised, the blind will move between these two positions, and when nearing the limit the blind will slowly come to rest and so avoid sudden stops which results in less stress on the components.

When the motor experiences a sudden increase in the energy absorption or a remarkable reduction of the motor speed, as a possible result of glass deflection (e.g. reduced cavity), the blind will stop. When this occurs all previous limits are over-ridden and the blind will wait till new ones are self-learned. When this unexpected stop occurs, and the cause of the blind to stop is resolved, the original end stop will be automatically reset and the blind will function normally.

Where it is deemed a faster recognition of the end stop by the motor is required, the following procedure must be followed (at least two times). Raise the blind by pressing the UP button; the blind raises and forms a stack at the top limit and then goes down a few millimetres, signalling that the end stop has been memorised. Then press the down button and wait till the blind reaches the lower limit and stops.

Where the blind stops before reaching the lower position, to reset the original end stop press the down button again until the blind goes down further and then comes to a sudden stop. The motor then memorises this lower position and will approach the limit more slowly when nearing this limit in future movements.

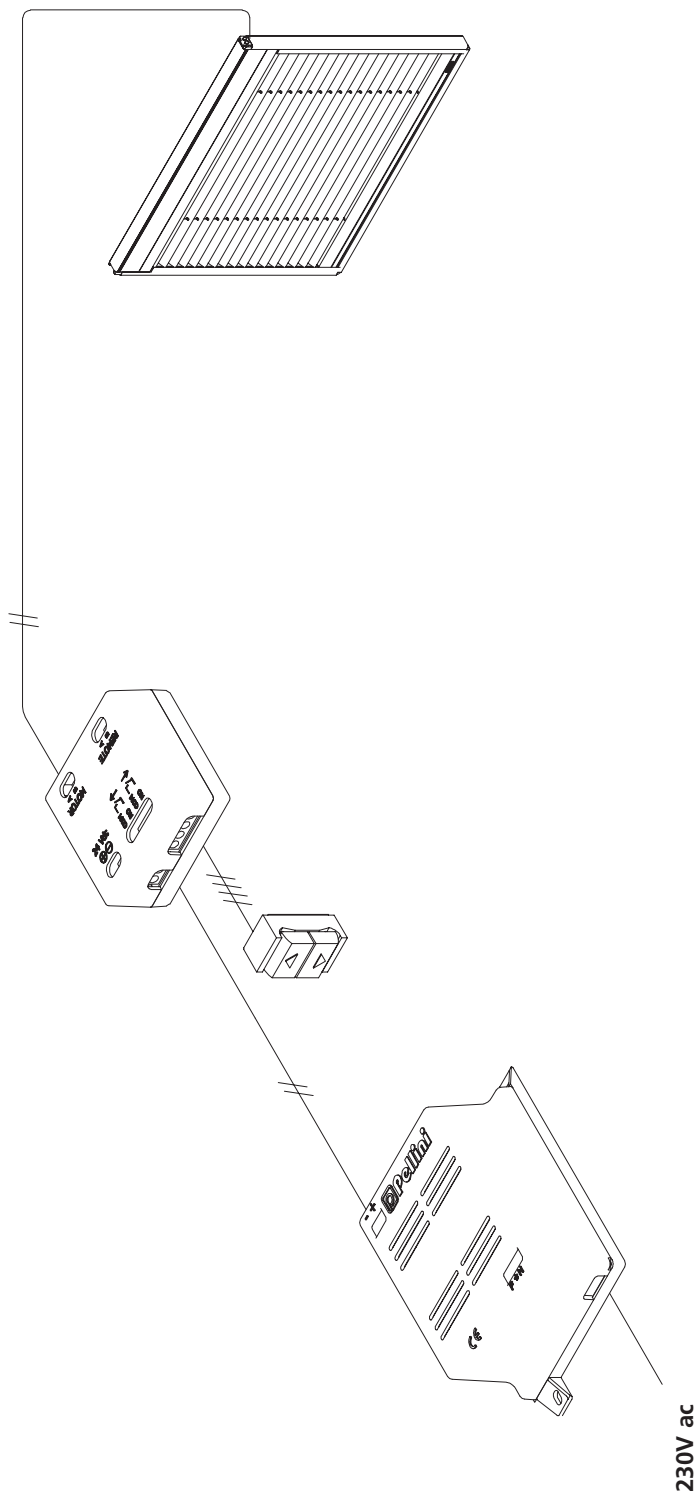

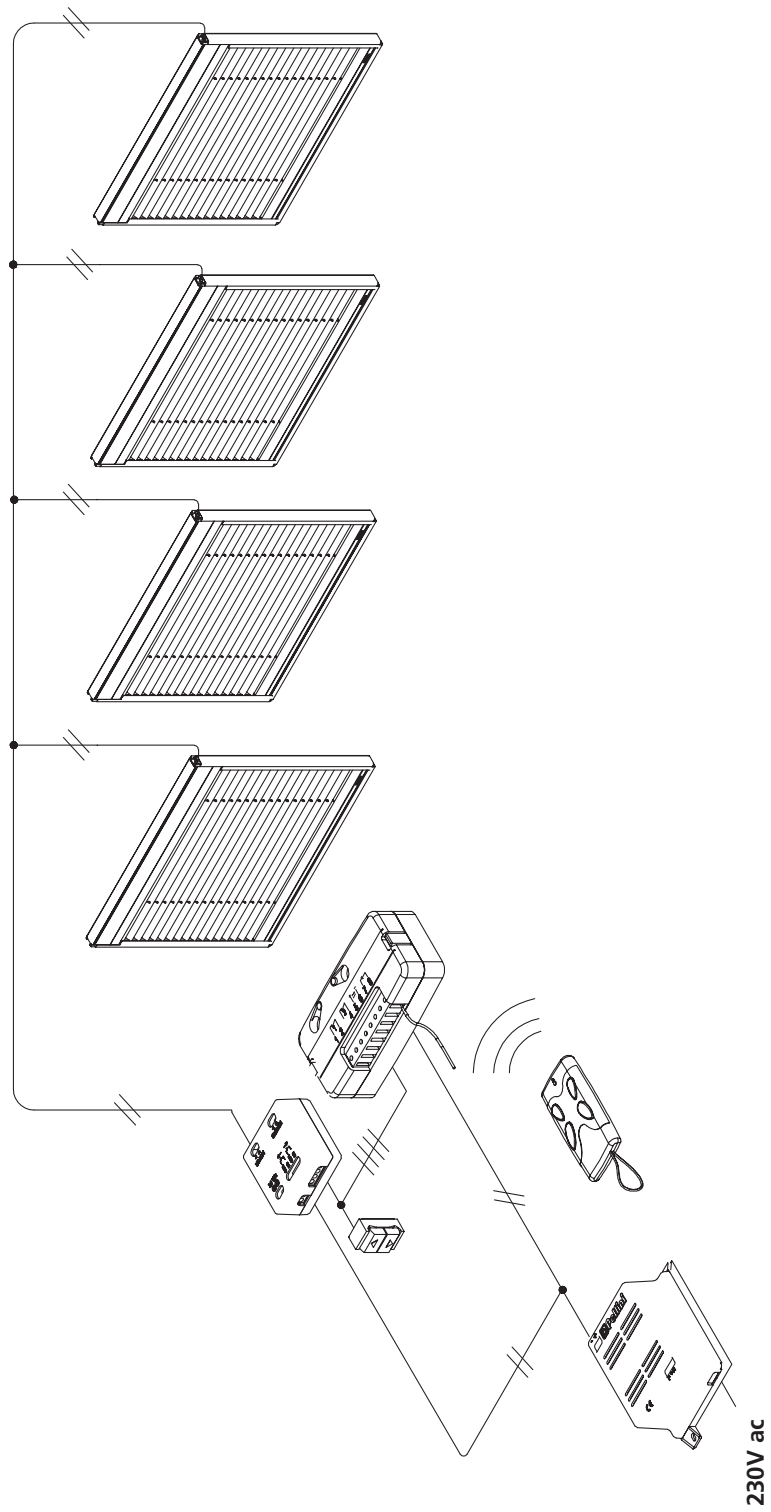

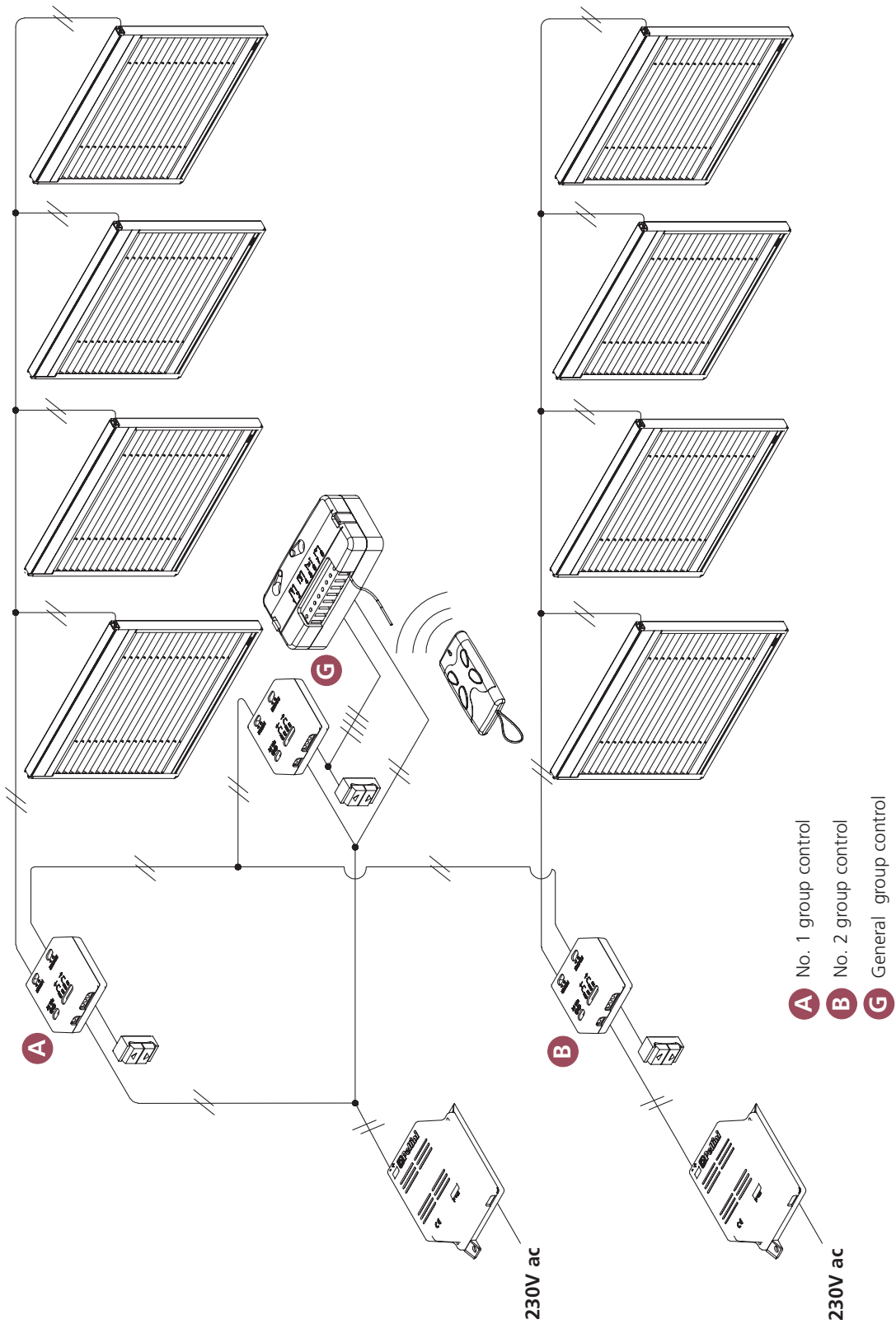

- A** No. 1 group control
- B** No. 2 group control
- G** General group control

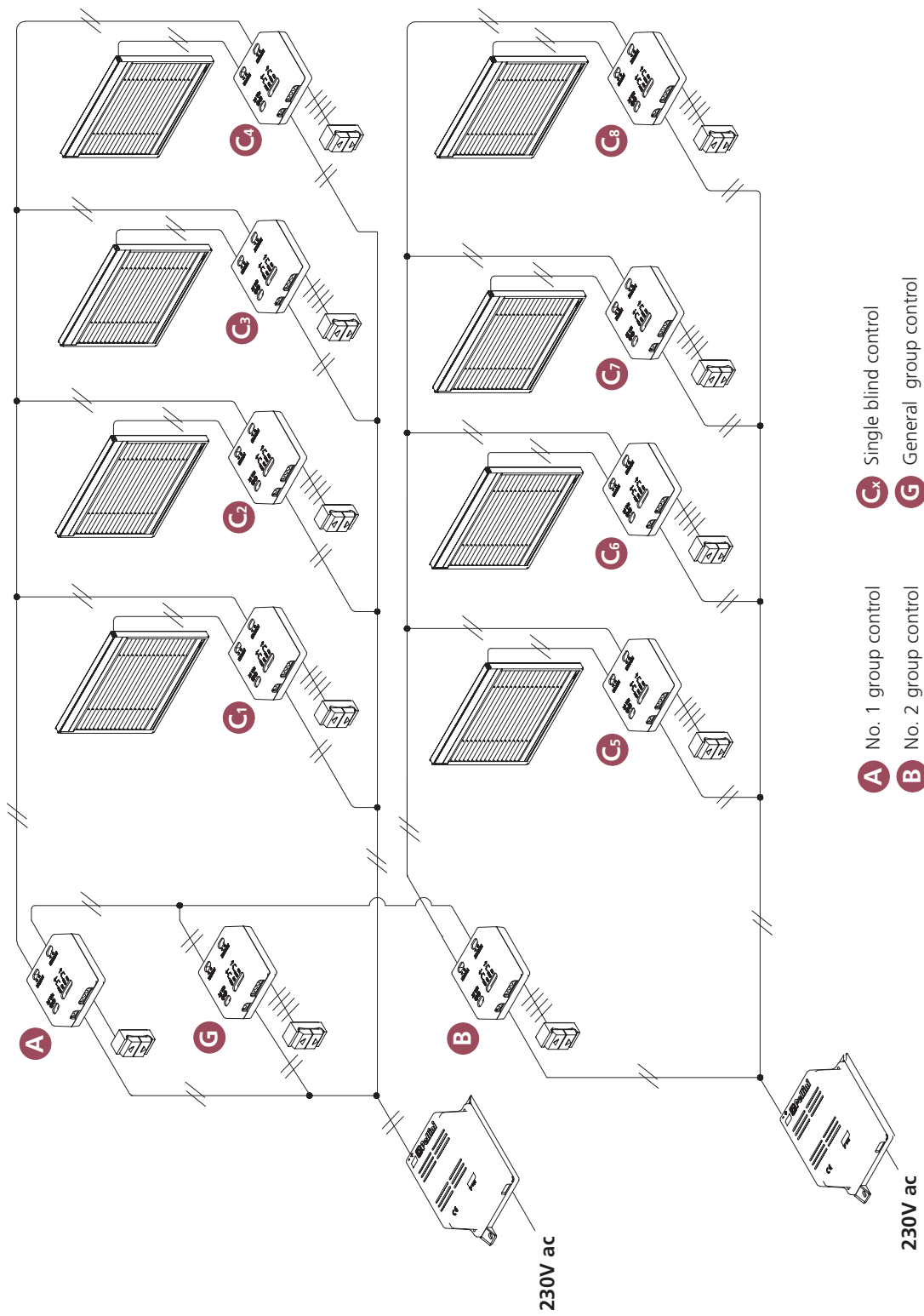

- A** No. 1 group control
- B** No. 2 group control
- Cx** Single blind control
- G** General group control

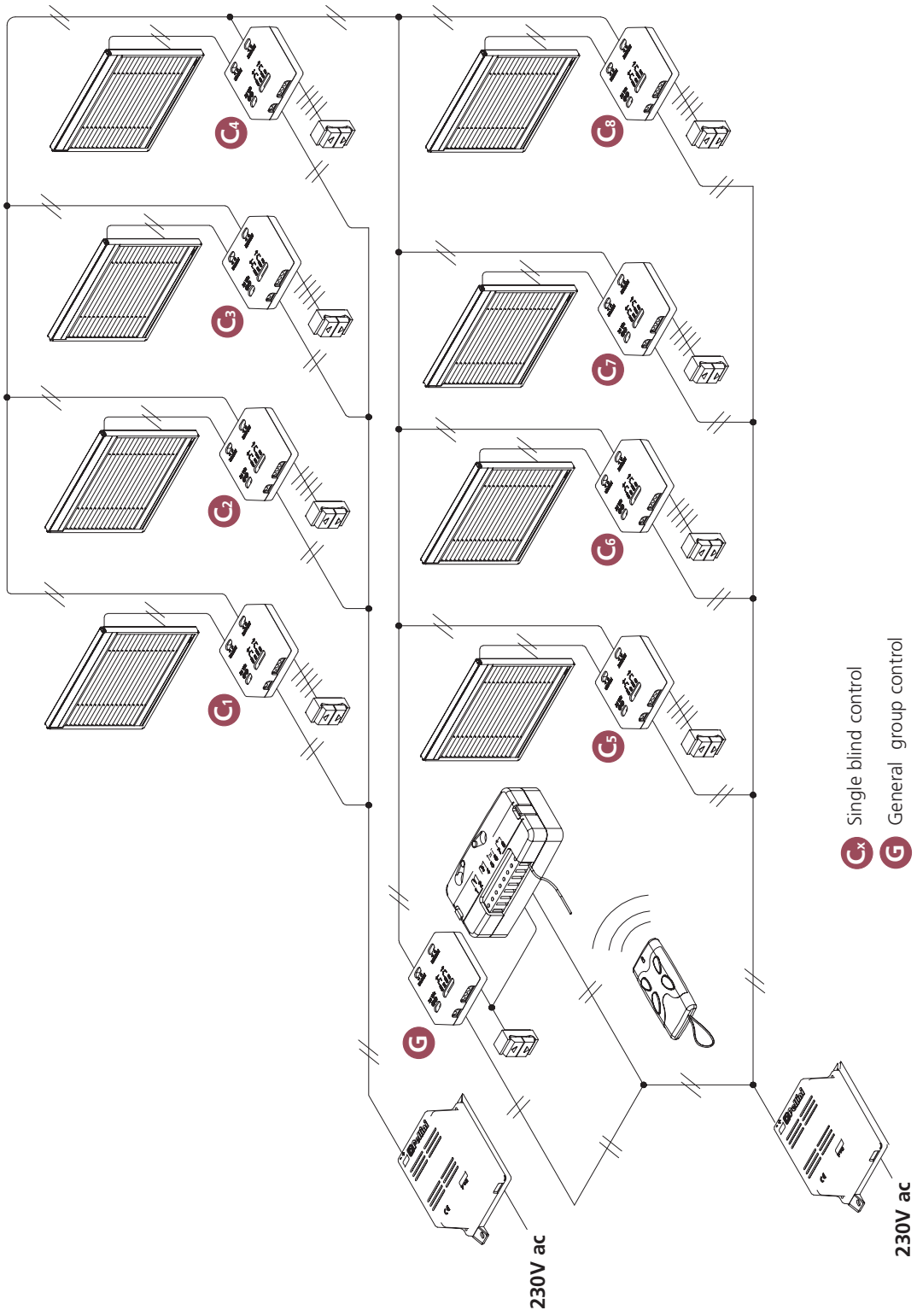

- C_x** Single blind control
- G** General group control



www.pellini.net

