

SL27C **ru**llo

ROLLER

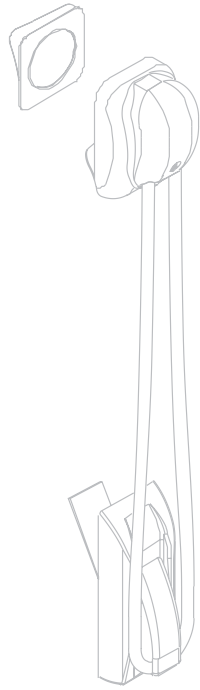

ScreenLine

SL27C rullo

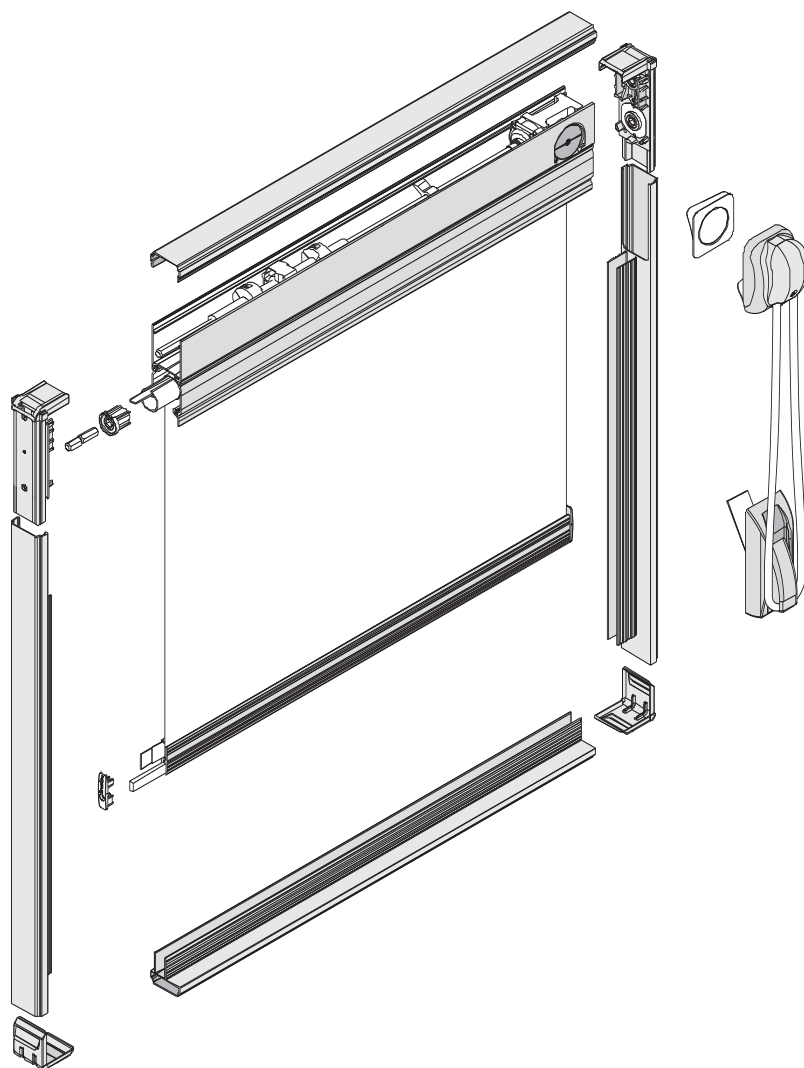

The ScreenLine® SL27 roller blind for use in double-glazed units, is manufactured in accordance with high technical specification and production standards. The roller blind operation is achieved using a rotational magnetic transmission through the glass thereby guaranteeing the unit's hermetic seal. The external magnet, fixed to the internal glass by double-sided high performance adhesive allows perfect alignment with the internal magnet. The raising and lowering operation is achieved using a continuous cord loop that drives the external magnet. The cord is held lightly under tension by a cord tensioner on the glass directly below the external magnet. A dedicated cover profile, completely encloses the fabric, and ensures the correct wrapping of the fabric on the drum. A dedicated double mechanical end stop ensures a safe stop of the blind at the extreme positions. The entire kit is completely contained within the spacer bar frame, guaranteeing the hermetical seal of the unit.

Height	300 ~ varies according to the fabric quality
Width	250 ~ 1.200 mm
Maximum area	see feasibility tables
Blind pack height	90 mm

1. technical features

Magnetic drive components

Fibreglass re-inforced nylon 66 casing. Transmission gears and parts manufactured from carbon-nitride steel. Ball bearing support for both magnets and gears.

Neodymium-Iron-Boron magnets with the following technical features:

Energy produced	Bh max-Mg.0e	33-35
Residual induction	Br-Gauss	11.000 / 12.000
Coercive force	Hc-Oestered	10.000
Maximum working temperature	°C	120
Curie temperature	°C	310
Reversible temperature factor	°C	-0.12%

Head rail

Extruded aluminium, A6063S-T5 alloy. Dimensions: width 27 mm, height 34 mm. Powder coated in aluminium grey colour.

Cover Profile

Extruded aluminium, A6063S-T5 alloy. Dimensions: width 8 mm, height 36 mm. Powder coated in aluminium grey colour.

Verosol® fabric

Woven polyester fabric with an aluminium microfilm applied through an exclusive vacuum coating technique (three-chamber system). The microfilm adhesion complies with the EN-ISO 7523 regulations and the fabric is Class 1 (one) Flame-Retardant - 19 colours available.

Performance characteristic of the Verosol® fabric

Pleated Verosol Fabric	Solar reflection %	Light reflection %	Solar absorption %	Solar transmission %	Light transmission %
812	71	66	20	9	9
816	52	50	28	20	22
875	74	74	21	5	5
837	63	62	36.6	0.4	0.4

Bottom rail

Extruded aluminium A6063S-T5 alloy. Dimensions: width 6 mm, height 25 mm. Powder coated to aluminium grey colour.

Spacer bars

Extruded aluminium spacer bars dimension 27 x 8 mm; top spacer with "U" shaped profile with 4.2 mm projection; bottom and side spacer with "C" spacer bars with 17 mm pelmet.

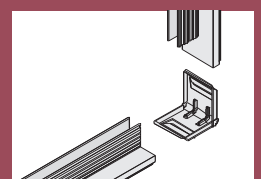
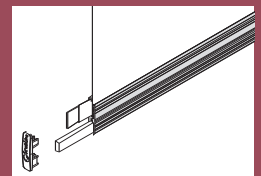
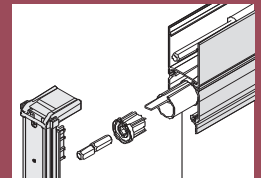
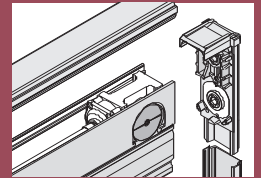

SL27C rullo

2. technical drawings

comprehensive drawing with component codes

SL27C rullo drawing with component codes

roller

SL27C

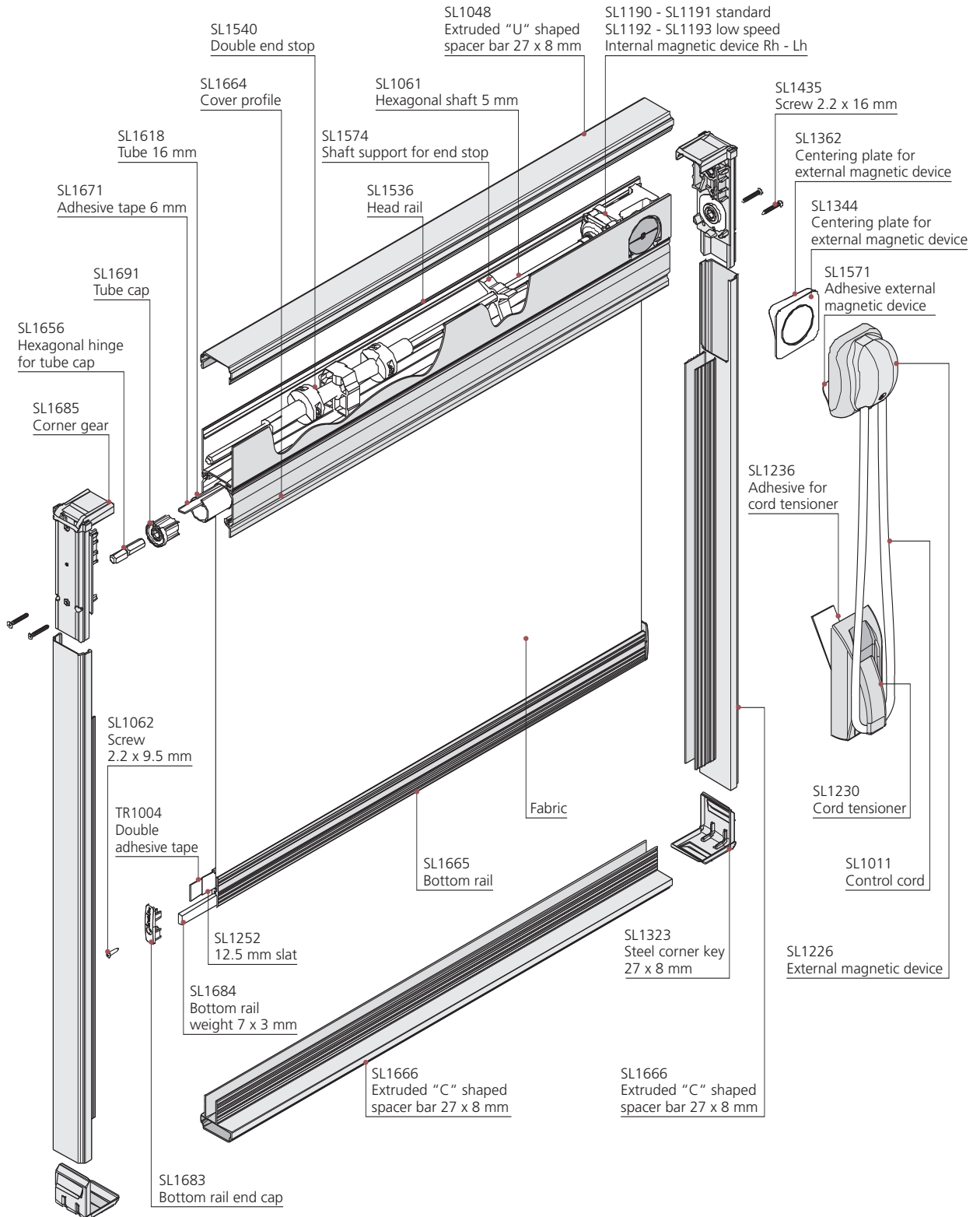

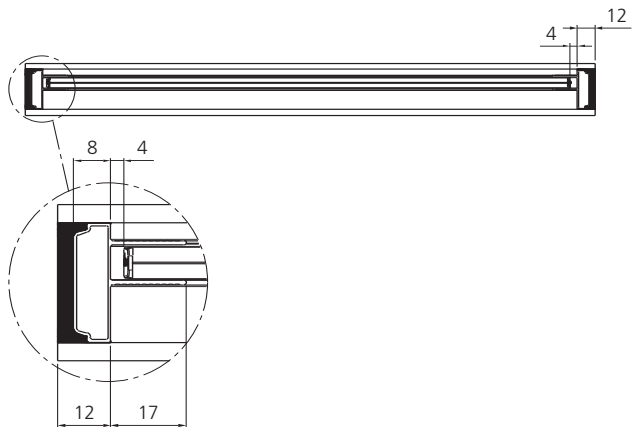
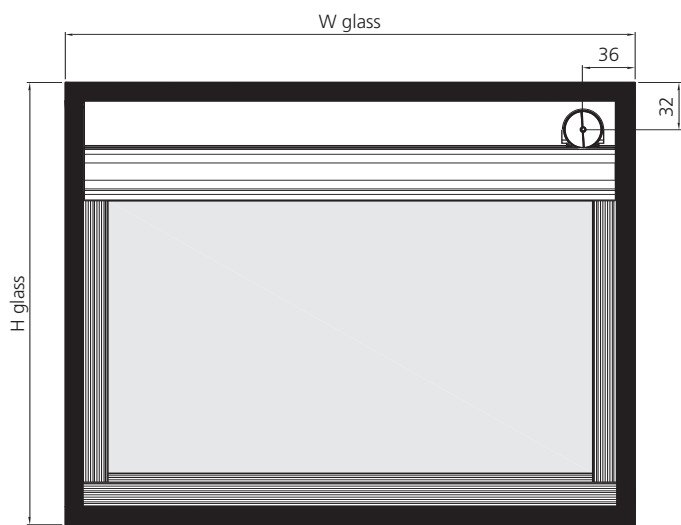

EXTRUDED "C" SPACER BAR
27 x 8 mm WITH 17 mm PELMET

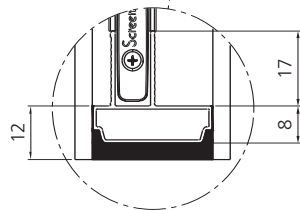
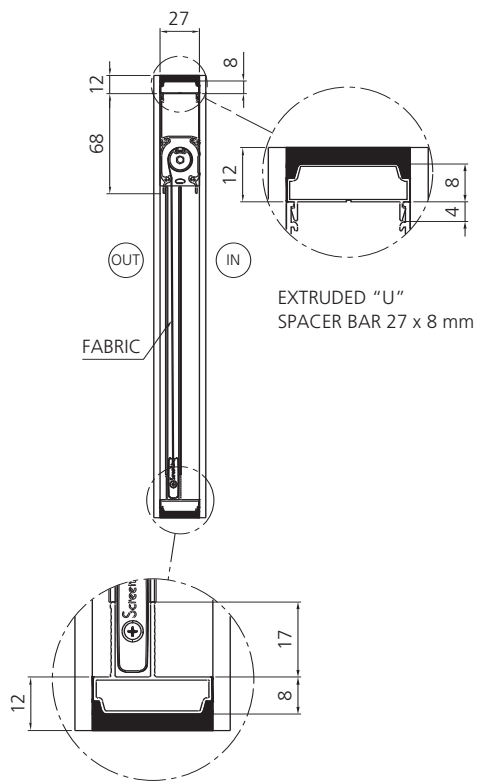

raising and lowering function

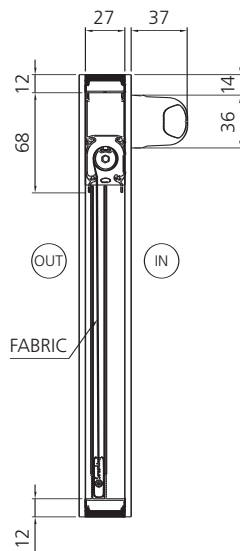
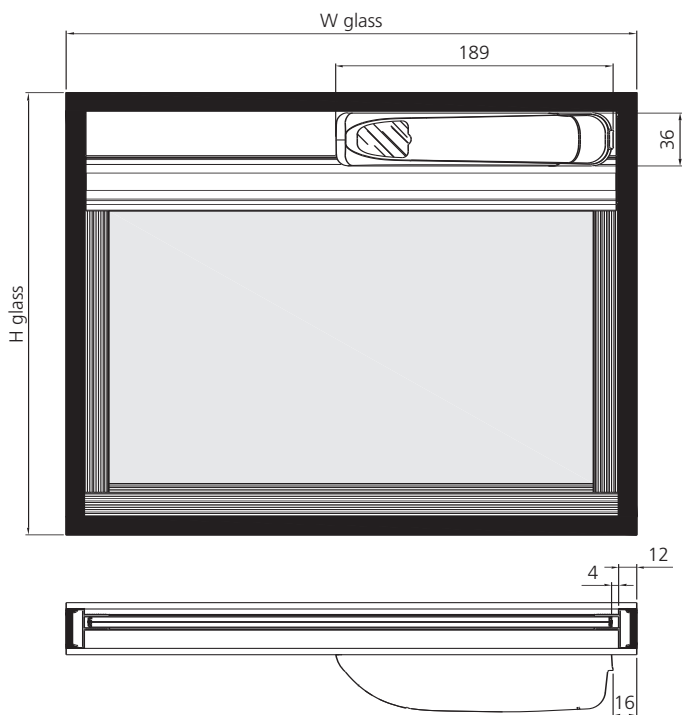
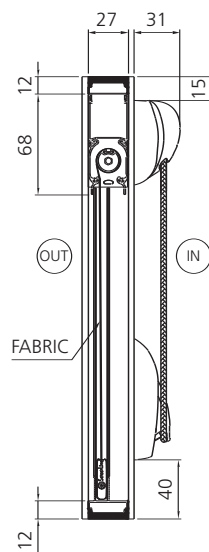
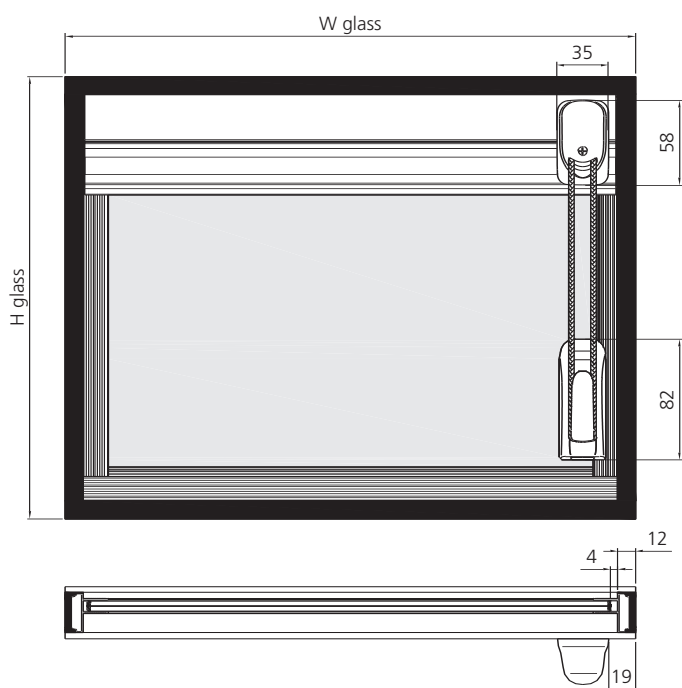

SL27C rullo

3. feasibility

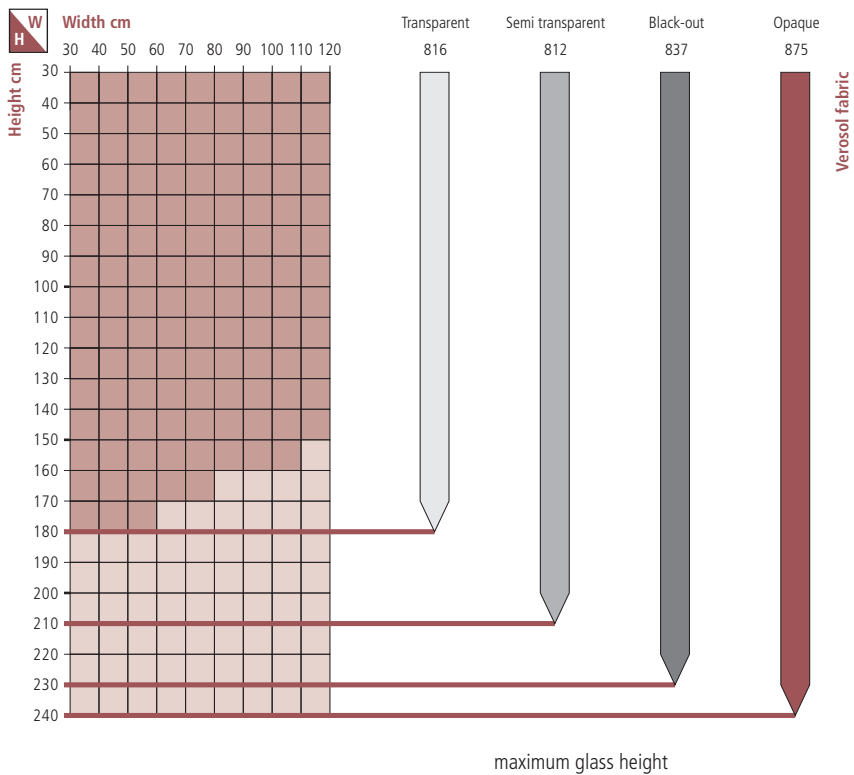
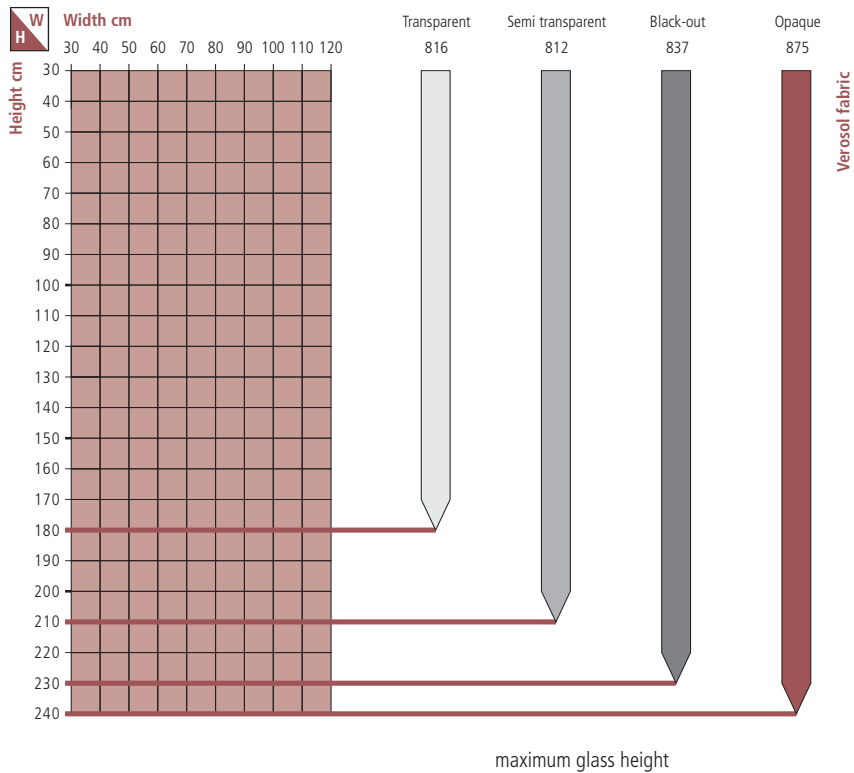

■ Raisable with standard speed System

■ Raisable with reduced speed System

4
9

glass thickness to 4 mm from 9 mm Laminated 44.1 44.2

10

glass thickness 10 mm Monolithic

SL27C rullo

feasibility

11
12

glass thickness **11 mm** Laminated **55.1 55.2 55.4** and **12 mm** Monolithic

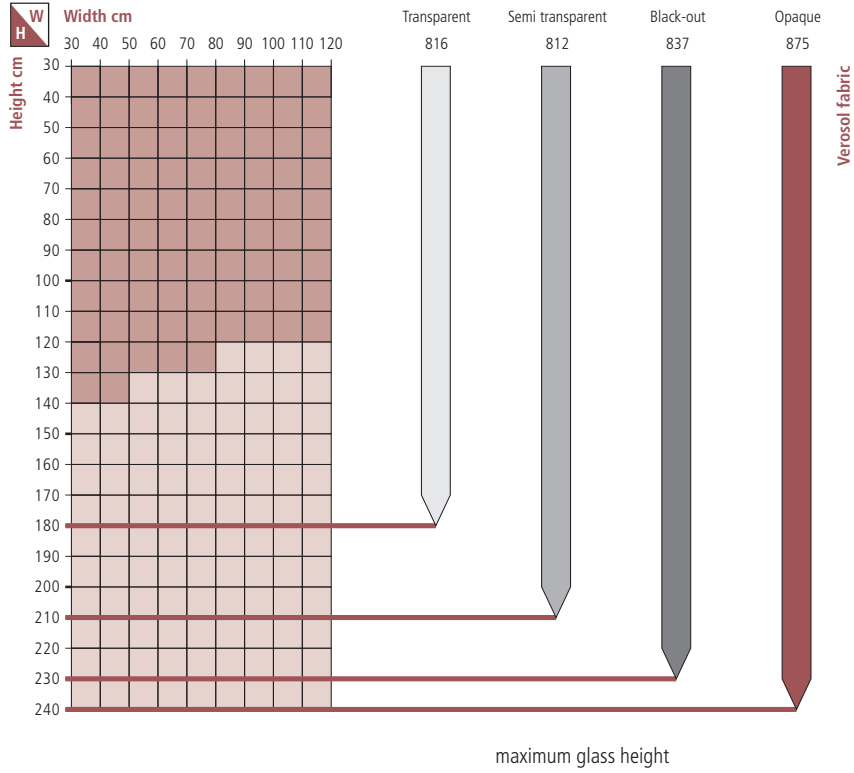

 Raisable with standard speed System

 Raisable with reduced speed System

www.pellini.net

